

# QT020

## Liquid Cooled Gas Engine Generator Sets

Standby Power Rating  
20 kW 60 Hz

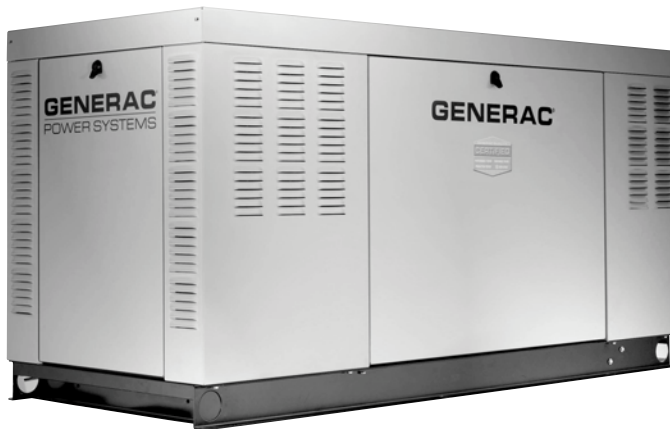

### GENERAC 1.5L ENGINE

Naturally Aspirated  
Gaseous Fueled

## STANDARD EQUIPMENT

- All input connections in one single area
- High coolant temperature shutdown
- Low oil pressure shutdown
- Low coolant level automatic shutdown
- Overspeed automatic shutdown
- Crank timer
- Exercise timer
- Oil drain extension
- Cool flow radiator
- Closed coolant recovery system
- UV/Ozone resistant hoses
- Watertight state of the art electrical connectors
- Mainline circuit breaker
- Radiator drain extension
- Battery charge alternator
- 2 Amp static battery charger
- Battery and battery cables
- Battery rack
- Fan and belt guards
- Isochronous governor

## FEATURES

- Innovative design and fully prototype tested
- UL2200 Listed
- Solid state frequency compensated voltage regulator
- Dynamic and static battery charger
- Sound attenuated acoustically designed enclosure
- Quiet test for low noise level exercise
- Acoustically designed engine cooling system
- High flow low noise factory engineered exhaust system
- State of the art digital control system with R100 digital control panel
- Watertight electrical connectors
- Rodent proof construction
- High efficiency, low distortion Generac designed alternator
- Vibration isolated from mounting base
- Matching Generac transfer switches engineered and tested to work as a system
- All components easily accessible for maintenance
- Electrostatically applied powder paint

**GENERAC**<sup>®</sup>  
POWER SYSTEMS, INC.

# APPLICATION & ENGINEERING DATA

QT020

## GENERATOR SPECIFICATIONS

TYPE .....	Synchronous
ROTOR INSULATION .....	Class F
STATOR INSULATION .....	Class F
TOTAL HARMONIC DISTORTION .....	<5%
TELEPHONE INTERFERENCE FACTOR (TIF) .....	<50
ALTERNATOR OUTPUT LEADS 3 PHASE .....	4 wire
BEARINGS .....	Sealed Ball
COUPLING .....	Flexible Disc
LOAD CAPACITY (STANDBY RATING) .....	20 kW
EXCITATION SYSTEM .....	Direct

**NOTE: Generator rating and performance in accordance with ISO8528-5, BS5514, SAE J1349, ISO3046, and DIN6271 standards.**

## VOLTAGE REGULATOR

TYPE .....	Electronic
SENSING .....	Single Phase
REGULATION .....	± 1%
FEATURES .....	V/F Adjustable Adjustable Voltage and Gain LED Indicators

## GENERATOR FEATURES

- Revolving field heavy duty generator
- Directly connected to the engine
- Operating temperature rise 120 °C above a 40 °C ambient
- Insulation is Class F rated at 130 °C rise
- All models are fully prototyped tested

## CONTROL PANEL FEATURES

- SEVEN LED INDICATOR LIGHTS
  - System ready
  - Low fuel pressure
  - Low battery
  - Low oil pressure
  - High coolant temp/low coolant temp
  - Overspeed
  - Overcrank
- ADDITIONAL FUNCTIONS
  - Utility sensing
  - Delay on utility failure for engine start
  - Engine warm-up before transfer
  - Delay to retransfer to utility
  - Engine cooldown timer
  - Exerciser not set
- INTERNAL FUNCTIONS:
  - 3 position switch (auto, off and manual)
  - 2 wire start for any transfer switch
  - Communicates with the Generac RTS transfer switch
  - Built-in 7 day exerciser
  - Selectable engine speed at exercise
  - Governor controller is built into the master control board
  - Temperature range -40 °C to 70 °C

## ENGINE SPECIFICATIONS

MAKE .....	Generac
MODEL .....	In line
CYLINDERS .....	4
DISPLACEMENT .....	1.5 Liter
BORE .....	2.97
STROKE .....	3.23
COMPRESSION RATIO .....	9.4:1
INTAKE AIR SYSTEM .....	Naturally Aspirated
VALVE SEATS .....	Replaceable
LIFTER TYPE .....	Hydraulic

## GOVERNOR SPECIFICATIONS

TYPE .....	Electronic
FREQUENCY REGULATION .....	Isochronous
STEADY STATE REGULATION .....	± 0.25
ADJUSTMENTS	
Speed .....	Yes
Droop .....	Yes

## ENGINE LUBRICATION SYSTEM

OIL PUMP .....	Gear
OIL FILTER .....	Full flow spin-on cartridge
CRANKCASE CAPACITY .....	4 Quarts

## ENGINE COOLING SYSTEM

TYPE .....	Closed
WATER PUMP .....	Belt driven
FAN SPEED .....	2550
FAN DIAMETER .....	15 inches
FAN MODE .....	Pusher

## FUEL SYSTEM

FUEL TYPE .....	Natural gas, propane vapor
CARBURETOR .....	Down Draft
SECONDARY FUEL REGULATOR .....	Standard
FUEL SHUT OFF SOLENOID .....	Standard
OPERATING FUEL PRESSURE .....	.5" - 14" H <sub>2</sub> O

## ELECTRICAL SYSTEM

BATTERY CHARGE ALTERNATOR .....	12V 30 Amp
STATIC BATTERY CHARGER .....	2 Amp
RECOMMENDED BATTERY .....	Group 26, 525CCA
SYSTEM VOLTAGE .....	12 Volts

Rating definitions - Standby: Applicable for supplying emergency power for the duration of the utility power outage. No overload capability is available for this rating. (All ratings in accordance with BS5514, ISO3046 and DIN6271). (All ratings in accordance with BS5514, ISO3046, ISO8528 and DIN6271).

QT020

## OPERATING DATA

		<b>QT020</b>		
<b>KW RATING</b>		20		
<b>ENGINE SIZE</b>		1.5 Liter 4 cyl. inline		
<b>GENERATOR OUTPUT VOLTAGE/KW - 60Hz</b>		<b>KW</b>	<b>AMP</b>	<b>CB Size</b>
120/240V, 1-phase, 1.0 pf		20	83	100
120/208V, 3-phase, 0.8 pf		20	69	80
<b>GENERATOR LOCKED ROTOR KVA AVAILABLE @ VOLTAGE DIP OF 35%</b> Single phase or 208 3-phase		34		
<b>ENGINE FUEL CONSUMPTION (Natural Gas) (Propane)</b>		<b>Natural Gas</b>	<b>Propane</b>	
		(ft <sup>3</sup> /hr.)	(gal/hr.)	cu ft/hr
Exercise cycle		60	0.65	24
25% of rated load		124	1.35	49
50% of rated load		188	2.05	75
75% of rated load		250	2.73	99
100% of rated load		315	3.44	125
<b>ENGINE COOLING</b>				
Air flow (inlet air including alternator and combustion air) ft <sup>3</sup> /min.		1,528		
System coolant capacity US gal.		2.0		
Heat rejection to coolant BTU/hr.		107,000		
Max. operating air temp. on radiator °C (°F)		60 (150)		
Max. ambient temperature °C (°F)		50 (140)		
<b>COMBUSTION AIR REQUIREMENTS</b>				
Flow at rated power 60 Hz cfm		91		
<b>SOUND EMISSIONS IN DBA</b>				
Exercising at 7 meters		62		
Full load at 7 meters		75		
<b>EXHAUST</b>				
Exhaust flow at rated output 60 Hz cfm		177		
Exhaust temp. at muffler outlet °F		910		
<b>ENGINE PARAMETERS</b>				
Rated synchronous RPM 60 Hz		3600		
HP at rated KW 60 Hz		34.8		
<b>POWER ADJUSTMENT FOR AMBIENT CONDITIONS</b>				
Temperature Deration				
3% for every 10 °C above - °C		25		
1.65% for every 10 °F above - °F		77		
Altitude Deration				
1% for every 100 m above - m		183		
3% for every 1000 ft. above - ft.		600		

RATING: All three phases units are rated at 0.8 power factor. All single phase units are rated at 1.0 power factor. STANDBY RATING: Standby ratings apply to installations served by a reliable utility source. The standby rating is applicable to varying loads for the duration of a power outage. There is no overload capability for this rating. Ratings are in accordance with ISO-3046-1. Design and specifications are subject to change without notice. KW rating is based on LPG Fuel and may derate with natural gas.

## C1 Enclosure 20-25 KW QT

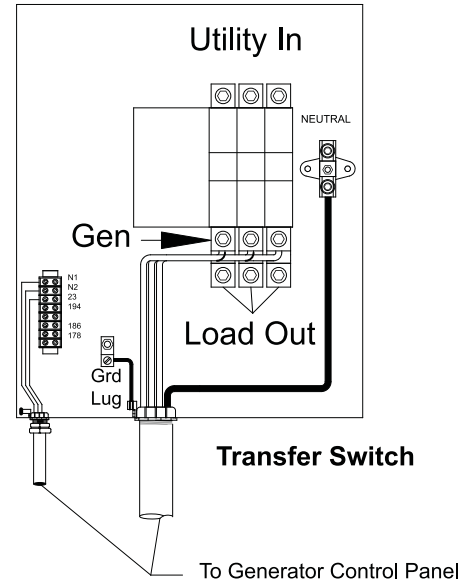
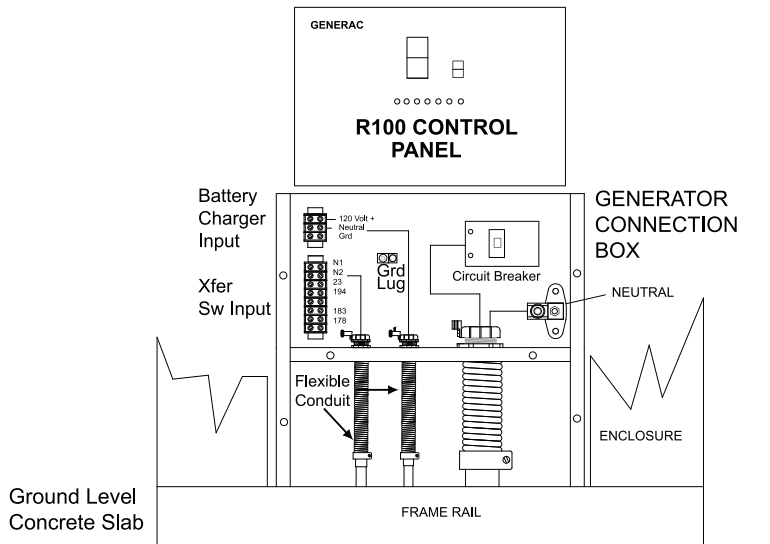

CIRCUIT BREAKER SIZE				
KW	VOLTS	/	AMPS	LUG SIZE
20	240	1 Ø	90	#6 to 1/0
20	208	3 Ø	80	#6 to 1/0

# INSTALLATION LAYOUT

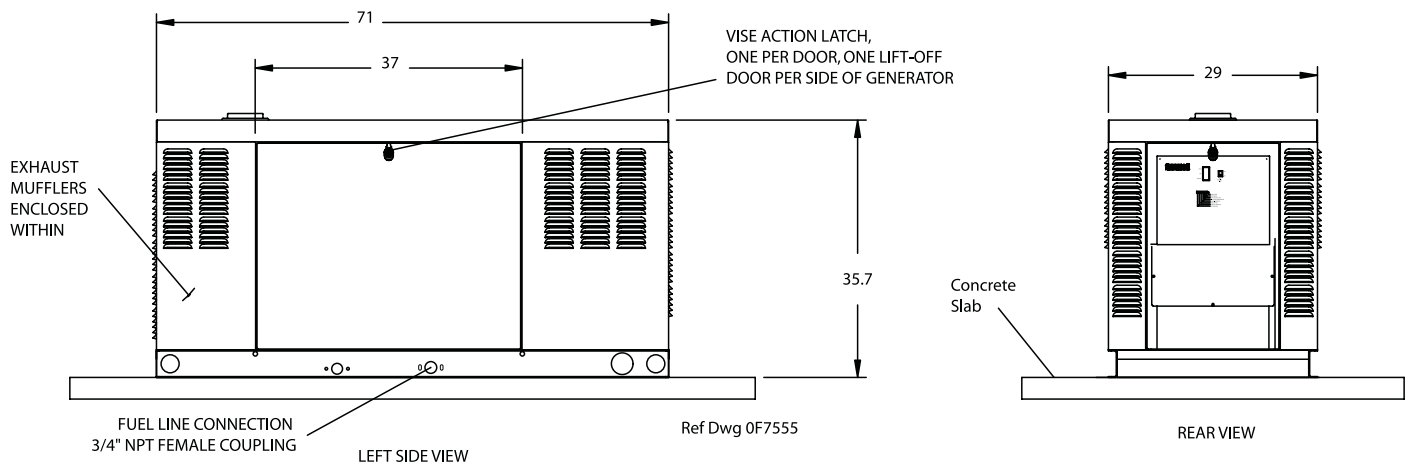

**GENERAC®** POWER SYSTEMS, INC. • P.O. BOX 8 • WAUKESHA, WI 53187  
 262/544-4811 • FAX 262/544-4851